

DUROsoft EM

Electronic Meter Initiated Softeners

OPERATION MANUAL

*PLEASE NOTE: On page seven of this manual you will find important maintenance procedures for the continued proper operation of your unit. These **MUST** be performed regularly for your guarantee to remain valid.*

DURO[®]

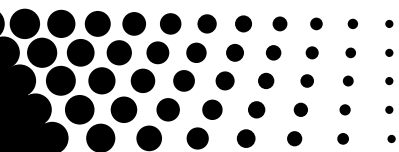

Performance

Item No.	Model No.	Capacity Grains			Flow Rate		Resin Tank Size Inches	Resin Volume Cu Ft	Cabinet/Brine Tank Size Inches W x D X H	Salt Capacity Lbs	Shipping Weight Lbs
		@ 10 lbs per cu ft	Factory set @ 6 lbs per cu ft	@ 3 lbs per cu ft	Service USGPM	Backwash USGPM					
6215	DC20EM	21,400	16,200	11,600	8	1.5	9 x 35	.75	14 x 22 x 42	250	90
6216	DC30EM	30,000	23,000	16,000	9	2	10 x 35	1	14 x 22 x 42	240	105
6210	DT20EM	21,400	16,200	11,600	8	1.5	9 x 35	.75	18 x 35	224	85
6211	DT30EM	30,000	23,000	16,000	9	2	10 x 35	1	18 x 35	224	100
6212	DT40EM	37,500	28,750	20,000	9	2	10 x 47	1.25	21 x 36	308	140
6213	DT60EM*	60,000	46,000	32,000	12	3	12 x 52	2	21 x 36	308	190
6214	DT90EM*	90,000	69,000	48,000	15	4	14 x 65	3	21 x 36	308	230

*Items include brine tank grid
DC indicates cabinet model, **DT** indicates twin tank model
 Maximum Water Temperature = 110°F (43°C)
 Maximum Operating Pressure = 100 PSIG (689 kPa)
 Voltage = 110 volts standard
 Pipe Size = 3/4"

- At the stated service flow rates, the pressure drop through these devices will not exceed 15 psig.
- Changing salt settings from factory setting may require changing injector sizes to achieve stated capacities.
- Do not use where water is microbiologically unsafe.
- The manufacturer reserves the right to make product improvements which may deviate from the specifications and descriptions stated herein, without obligation to change previously manufactured products or to note the change.

How Your EM Water Softener Works

Hard water enters your home through the main supply line, enters the softener and passes down through a resin mineral bed which softens the water. An ion exchange process takes place in which the resin beads capture and hold calcium and magnesium, the hardness minerals, while the water takes on sodium ions. The soft water then flows into your household water line.

In normal operation, the Time of Day display will alternate being viewed with the Volume Remaining display. This display will be in gallons. As treated water is used, the Volume Remaining display will count down from a maximum value to zero or (---). Once this occurs, a regeneration cycle will then be initiated at the Set Regeneration Time. Water flow through the valve is indicated by the Flow Dot that will flash in direct relationship to flow rate.

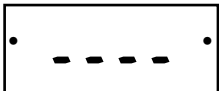
Example	833 Gallons of Treated Water Remaining	Service		Flow
		Program		P.M.
	0 Gallons of Treated Water Remaining	Service		Flow
		Program		P.M.

In regeneration the control will display a special Regeneration Display. In this display, the control will show the current regeneration step number the valve is advancing to or has reached and the time remaining in that step. The step number displayed will flash until the valve has completed driving to this regeneration step position. Once all regeneration steps have been completed, the valve will return to Service and resume normal operation.

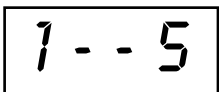
Example	Less than 6 minutes remain in Regen Step #1	Service		Flow
		Program		P.M.

Pushing the Extra Cycle Button during a regeneration cycle will immediately advance the valve to the next cycle step position and resume normal step timing.

Control Operation During Programming

The control will only enter the Program Mode with the valve in Service. While in the Program Mode, the control will continue to operate normally, monitoring water usage and keeping all displays up to date. Control programming is stored in memory permanently, eliminating the need for battery back-up power.

Control Operation During a Power Failure

During a power failure, all control displays and programming will be stored for use upon power re-application. *The control will retain these values for years, if necessary, without loss.* The control will be fully inoperative and any calls for regeneration will be delayed. The control will, upon power re-application, resume normal operation from the point where it was interrupted. *An indication that a power outage has occurred will be an inaccurate Time of Day display.*

Installation Instructions

CAUTION: If the ground from the electrical panel or breaker box to the water meter or underground copper pipe is tied to the copper water lines and these lines are cut during installation of the Noryl bypass valve and/or poly pipe, an approved grounding strap must be used between the two lines that have been cut in order to maintain continuity. The length of the grounding strap will depend upon the number of units being installed and/or the amount of copper pipe being replaced with poly. See Figure 1.

In all cases where metal pipe was originally used and is later interrupted by poly pipe or the Noryl bypass valve, as in Figure 1 or by physical separation as in Figure 2, to maintain proper metallic pipe bonding, an approved ground clamp c/w not less than #6 copper conductor must be used for continuity.

Check your local electrical code for the correct clamp and cable size.

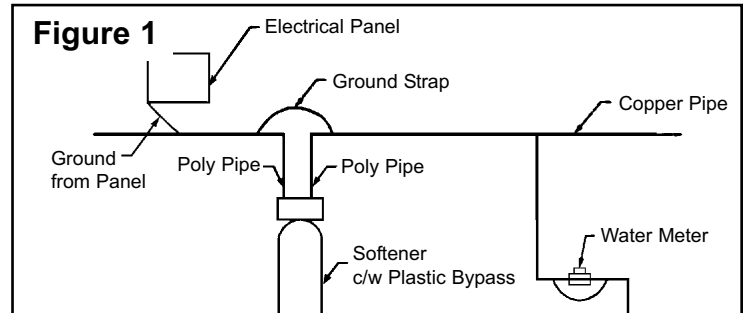

1. Determine the best location for your water softener, bearing in mind the location of your water supply lines, drain line and 110/120 volt AC electrical outlet. Subjecting the softener to freezing or temperatures above 49°C (120°F) will void the warranty.

Media Installation (When Necessary)

- Remove the valve from the mineral tank.
 - Temporarily plug the open end of the riser tube to ensure that no resin or gravel falls down into the distribution.
 - Fill mineral tank one quarter full of water to protect distribution during gravel installation.
 - Slowly and carefully add the gravel support bed and the softener media leveling each layer as it is placed into the tank.
 - Unplug the riser tube, carefully position the valve over it and turn the valve into the threads in the fiberglass tank, tightening securely into tank. Note: Ensure that the internal O-ring in the valve fits securely over the riser tube. Silicone grease (#13691) or other food grade lubricant may be applied to the O-ring to ease installation of the riser tube. DO NOT use petroleum based lubricants as they will cause swelling of O-rings and seals.
 - The softener is now charged with softening resin.
 - It is recommended that the softener tank now be completely filled with water (SLOWLY) to soak the resin before startup. This will allow the media to absorb water as well as help displace any trapped air. This will reduce the chance of backwashing resin out during startup.
2. Water to supply outside faucets used to water lawns and gardens should not be softened. A new water line is often required to be connected to supply hard water to the inlet of the water softener and to the outside faucets. Cut the water line between where it enters the house, before any lines that branch off to feed water heater or other fixtures in the house, and as near the desired location of the water softener as possible. Install a tee fitting on the feed end of the cut pipe and an elbow fitting on the other end. Install piping from the tee of the water softener and from the elbow to the outlet to the softener. To sever the water lines which branch off to feed any outside faucets, cut the branch lines approximately two inches from the fitting on the main water line. Install an elbow on the end of the pipe nearest the outside faucet and a cap on the end connected to the existing water line. Install piping from the tee on the inlet line to the water softener to the elbow installed on the pipe to the outside faucet. Following this procedure will result in all lines in the house, with the exception of the outside faucets, but including the water heater and therefore the hot water lines, being supplied with soft water.

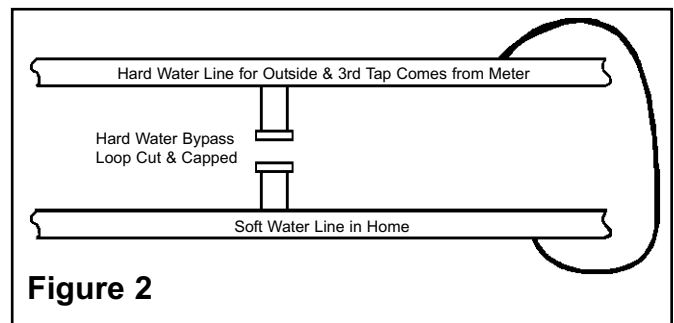

Installation Instructions Cont'd

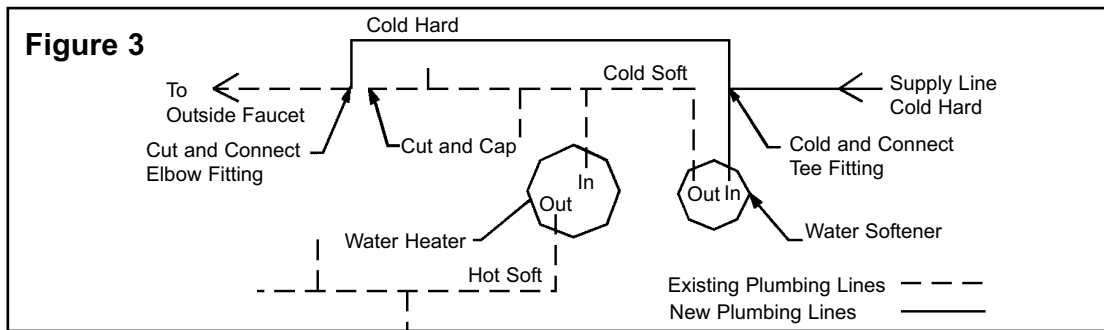

3. On cabinet models, lift off the control valve cover and the salt cover to expose the control valve. The electronic control module in the control valve cover remains connected to the control valve by means of the wiring harness. Familiarize yourself with the location of the inlet, outlet and drain on the control valve. Be very careful not to get the controls wet.
4. Attach the bypass valve to the control valve. Connect the inlet and outlet of the water softener to the plumbing in the house. The control valve must not be submitted to temperatures above 71°C (160°F). When sweat fittings are used, to avoid damaging the control valve, solder the threaded copper adapters to the copper pipe and then using Teflon tape screw the assembly into the bypass valve. **CAUTION** - do not use pipe thread compound as it may attack the material in the valve body.
5. Using teflon tape, screw the 1/2" hose barb into the drain port in the valve. Attach 1/2" drain hose to the hose barb and tighten securely with a hose clamp. Run the drain line to a floor drain or a laundry drain using an airgap or other acceptable method to prevent cross-connection between your potable water system and your sewage system. Complete any necessary plumbing.
6. On twin tank units, pull the 3/8" brine line through the hole in the back of the brine tank. Connect the brine line to the fitting on the side of the valve using the nut and ferrule. Tighten snugly.
7. Make sure the bypass valve is in the service position.
8. Plug the 24 volt transformer into a 120 VAC 60 Hz outlet. The valve has 4 positions 1) Brine / slow rinse 2) Backwash 3) Rapid Rinse (not used in this configuration) 4) Brine Refill. When the valve is in the Service position, the *extra cycle* button (far left button as shown on Figure 4) must be pressed and held for 5 seconds to advance the valve into Position "1" Brine / slow rinse (1...59). Press the *extra cycle* button again to advance the valve into Position "2" - Backwash (2...9). Slowly turn on the water supply and allow the unit to backwash until the air purges out of the tank and clears the system.
9. Press the *extra cycle* button and wait for the valve to advance to position 4 - Brine Fill and allow the brine tank to fill until there is 6" of water in the brine tank.
10. Press the *extra cycle button* to advance the valve to Service position. Press and hold manual cycle button again for 5 seconds to advance the valve to Position 1 - Brine / slow rinse. Verify that there is brine being drawn from the tank. If not, repeat step 9 through 10 or see Cleaning the Injector Assembly on Page 7 of this manual.
11. Press the *extra cycle button* to advance the valve to position "2" Backwash position and then press the *extra cycle* button again to advance the valve to Position 4 - Brine fill. Additional water can be added manually at this time to achieve this level, however, the valve needs to be in the brine fill position to allow all air to be purged from the pressure regulator and injector set.
12. Press the *extra cycle button* to advance the valve to the Service position.
13. Put 40 kgs of crystal water softener salt in the brine tank. The unit will automatically fill to correct level when it regenerates.
14. Before replacing the control valve cover and salt cover on cabinet models, ensure the wiring harness is securely plugged into the circuit in the electronic control module. The unit will regenerate automatically as needed.

Optional Sanitization Procedure: We recommend that all new water conditioners be disinfected as part of the startup. Sanitization is achieved by the application of chlorine in the regeneration cycle of the conditioner. A liquid solution of 5.25% sodium hypochlorite (commonly referred to as household bleach) is recommended as a suitable disinfectant. Use only unscented products. For every cubic foot of resin in the softener, pour approximately two (2) tablespoons of sodium hypochlorite into the brine well tube. The brine tank refill in Step 12 should add the correct amount of water to the brine tank. If not, the water can be added manually now. Press and hold the EXTRA CYCLE button to begin a manual regeneration. Press the EXTRA CYCLE button again to advance the valve to the Brine/Rinse position. Allow softener to complete the Brine/Rinse cycle, then let the manual regeneration continue until the brine tank is refilled again with the correct amount of water.

ALL STATE AND LOCAL GOVERNMENT CODES GOVERNING INSTALLATIONS OF THESE DEVICES MUST BE OBSERVED.

Operating Instructions

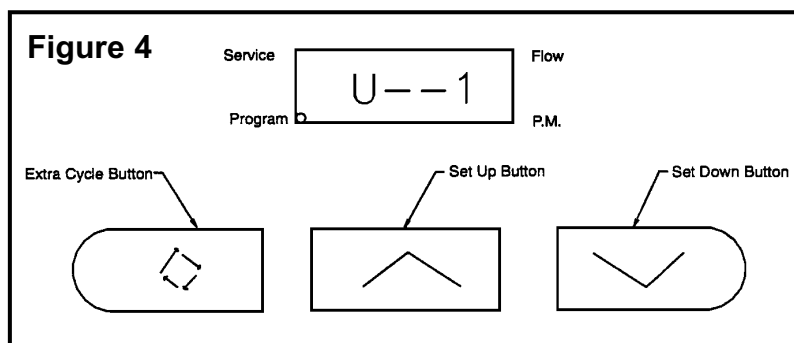

The valve has been pre-programmed with factory settings as follows:

- US Format**{U--1} US Gallons
- Regeneration Type**{7--3} Meter Delayed
- Regeneration Time**{2:00} A.M. Indicator On
- Regeneration Day Override**.....{A--Off}
- Regeneration Cycle Step Programming**

- 1. Brine Rinse.....60 minutes
- 2. Backwash.....10 minutes
- 3. Rapid Rinse.....0 minutes
- 4. Brine Refill6 minutes - .75 cu.ft.
.....8 minutes - 1.0 cu.ft.
.....10 minutes - 1.25 cu.ft.
.....8 minutes - 2.0 cu.ft.
.....12 minutes - 3.0 cu.ft.

- Flow Meter Size**{F133} 3/4" turbine flow meter assembly
- Line Frequency**.....{LF60} 60 Hz line frequency

Set Time of Day

Refer to Figure 4. Push either the UP or DOWN keys to adjust the time of day by one digit. Press and hold either UP or DOWN key to adjust time of day by several digits.

Enter Control Programming Mode

NOTE: Use the formula in STEP 2 to calculate the proper capacity setting for your softener OR consult the Quick Reference charts on the following page.

- 1. Push and hold for 5 seconds both the UP and DOWN keys to enter Programming Mode.
- 2. The first option display to appear is the Treated Water Capacity. To calculate the Treated Water Capacity, use the following formula:

$$\text{Unit Capacity in Grains (see Performance - Page 1) } \div \text{ water hardness (gpg) } = \text{ _____ gallons}$$
$$\text{ _____ gallons - (75 gallons x number of people in the household) } = \text{ _____ Treated Water Capacity to be set.}$$

Example: 23,000 grain capacity unit, 20 gpg water hardness, 4 people in household
23,000 grains \div 20 gpg = 1,150 gallons
1,150 gallons - (75 gallons x 4) = 850 gallons

Set Treated Water Capacity to 850 gallons

- 3. Push the *Extra Cycle* button to advance to the second option setting. The setting that appears is the Regeneration Time. Use the UP or DOWN keys to set the desired time of day for regeneration. The default setting is 2:00 A.M.
- 4. Push the Extra Cycle button. The third option setting display that appears is Regeneration Day Override. Use the UP or DOWN keys to set the maximum days before a regeneration cycle must occur. The default is {A--Off}. **This is an option only, please do not adjust before consulting an authorized dealer.**
- 5. The Control Programming is now complete. Push the Extra Cycle button. This will exit the control from the Programming Mode and resume to normal operation.

QUICK REFERENCE SOFTENER GALLONS CAPACITY SETTING CHARTS

Instructions: To use this chart, line up the actual number of people living in the residence in the left column with the total hardness in grains per USGallon across the top to arrive at the gallon setting.

If the water to the home is tested to have a hardness in between the numbers in the chart, then use the next highest hardness value.

DC20EM and DT20EM		Total Hardness (grains / USGallon)											
		10	15	20	25	30	35	40	45	50	55	60	65
# of People Living in the Residence	1	1650	1075	788	615	500	418	356	308	270	239	213	190
	2	1575	1000	713	540	425	343	281	233	195	164	138	115
	3	1500	925	638	465	350	268	206	158	120	Softener may be undersized. Consider a larger capacity model.		
	4	1425	850	563	390	275	193	131					
	5	1350	775	488	315	200	118						
	6	1275	700	413	240	125							

DC30EM and DT30EM		Total Hardness (grains / USGallon)													
		10	15	20	25	30	35	40	45	50	55	60	65	70	75
# of People Living in the Residence	1	2225	1458	1075	845	692	582	500	436	385	343	308	279	254	232
	2	2150	1383	1000	770	617	507	425	361	310	268	233	204	179	157
	3	2075	1308	925	695	542	432	350	286	235	193	158	129	104	
	4	2000	1233	850	620	467	357	275	211	160	118	Softener may be undersized. Consider a larger capacity model.			
	5	1925	1158	775	545	392	282	200	136						
	6	1850	1083	700	470	317	207	125							
	7	1775	1008	625	395	242	132								
	8	1700	933	550	320	167									
	9	1625	858	475	245										

DT40EM		Total Hardness (grains / USGallon)													
		10	15	20	25	30	35	40	45	50	55	60	65	70	75
# of People Living in the Residence	1	2800	1842	1363	1075	883	746	644	564	500	448	404	367	336	308
	2	2725	1767	1288	1000	808	671	569	489	425	373	329	292	261	233
	3	2650	1692	1213	925	733	596	494	414	350	298	254	217	186	158
	4	2575	1617	1138	850	658	521	419	339	275	223	179	142	111	
	5	2500	1542	1063	775	583	446	344	264	200	148	104	Softener may be undersized. Consider a larger capacity model.		
	6	2425	1467	988	700	508	371	269	189	125					
	7	2350	1392	913	625	433	296	194	114						
	8	2275	1317	838	550	358	221	119							
	9	2200	1242	763	475	283	146								
	10	2125	1167	688	400	208									

DT60EM		Total Hardness (grains / USGallon)													
		10	15	20	25	30	35	40	45	50	55	60	65	70	75
# of People Living in the Residence	1	4525	2992	2225	1765	1458	1239	1075	947	845	761	692	633	582	538
	2	4450	2917	2150	1690	1383	1164	1000	872	770	686	617	558	507	463
	3	4375	2842	2075	1615	1308	1089	925	797	695	611	542	483	432	388
	4	4300	2767	2000	1540	1233	1014	850	722	620	536	467	408	357	313
	5	4225	2692	1925	1465	1158	939	775	647	545	461	392	333	282	238
	6	4150	2617	1850	1390	1083	864	700	572	470	386	317	258	207	163
	7	4075	2542	1775	1315	1008	789	625	497	395	311	242	183	132	
	8	4000	2467	1700	1240	933	714	550	422	320	236	167	108		
	9	3925	2392	1625	1165	858	639	475	347	245	161				
	10	3850	2317	1550	1090	783	564	400	272	170					

DT90EM		Total Hardness (grains / USGallon)													
		10	15	20	25	30	35	40	45	50	55	60	65	70	75
# of People Living in the Residence	1	6825	4525	3375	2685	2225	1896	1650	1458	1305	1180	1075	987	911	845
	2	6750	4450	3300	2610	2150	1821	1575	1383	1230	1105	1000	912	836	770
	3	6675	4375	3225	2535	2075	1746	1500	1308	1155	1030	925	837	761	695
	4	6600	4300	3150	2460	2000	1671	1425	1233	1080	955	850	762	686	620
	5	6525	4225	3075	2385	1925	1596	1350	1158	1005	880	775	687	611	545
	6	6450	4150	3000	2310	1850	1521	1275	1083	930	805	700	612	536	470
	7	6375	4075	2925	2235	1775	1446	1200	1008	855	730	625	537	461	395
	8	6300	4000	2850	2160	1700	1371	1125	933	780	655	550	462	386	320
	9	6225	3925	2775	2085	1625	1296	1050	858	705	580	475	387	311	245
	10	6150	3850	2700	2010	1550	1221	975	783	630	505	400	312	236	170

Notes: Chart is based on a 3 day sizing method shown on previous page of this manual.

If application falls outside the parameters of this chart, then use the formula on the previous page of this manual to calculate the proper gallon setting.

Automatic Bypass

The regeneration cycle lasts approximately 2-1/2 hours after which soft water service will be restored. During regeneration, hard water is automatically bypassed for use in the household. Hot water should be used as little as possible during this time to prevent hard water from filling the water heater. This is why the automatic regeneration is set for sometime during the night and manual regenerations should be performed when little or no water will be used in the household.

Safety Float

The brine tank is equipped with a safety float which prevents your brine tank from overflowing as a result of a malfunction such as a power failure.

Water Pressure

Your softener is designed to be operated under normal water pressures from 20 psi to 120 psi.

New Sounds

You may notice new sounds as your water softener operates. During this time, you may hear water running intermittently to the drain.

Manual Bypass (Figure 5)

In case of an emergency such as an overflowing brine tank, you can isolate your water softener from the water supply using the bypass valve located at the back of the control.

In normal operation the bypass is open with the ON/OFF knobs in line with the INLET and OUTLET pipes. To isolate the softener, simply rotate the knobs clockwise (as indicated by the word BYPASS and arrow) until they lock.

You can use your water related fixtures and appliances as the water supply is bypassing the softener. However, the water you use will be hard.

To resume soft water service, open the bypass valve by rotating the knobs counter-clockwise.

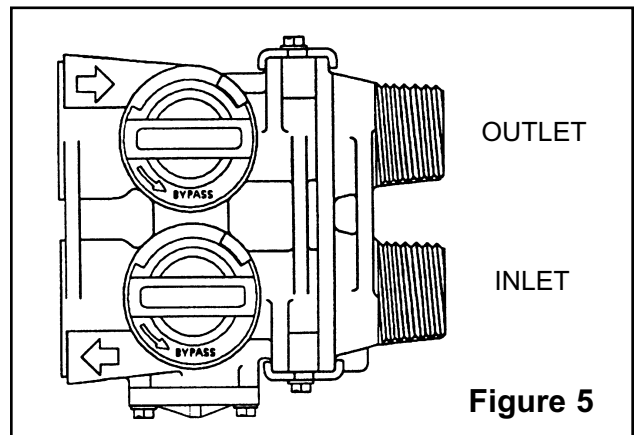

Maintenance

Adding Salt

Use only crystal water softener salt. Check the salt level monthly. It is important to maintain the salt level above the water level. To add salt, simply lift the salt lid and add the salt directly into the brine tank. Be sure the brine well cover is on and fill only to the height of the brine well.

Bridging (Figure 6)

Humidity or the wrong type of salt may create a cavity between the water and the salt. This action, known as “bridging”, prevents the brine solution from being made, leading to your water supply being hard.

If you suspect salt bridging, carefully pound on the outside of the plastic brine tank or pour some warm water over the salt to break up the bridge. This should always be followed up by allowing the unit to use up any remaining salt and then thoroughly cleaning out the brine tank.

Allow four hours to produce a brine solution, then manually regenerate the softener.

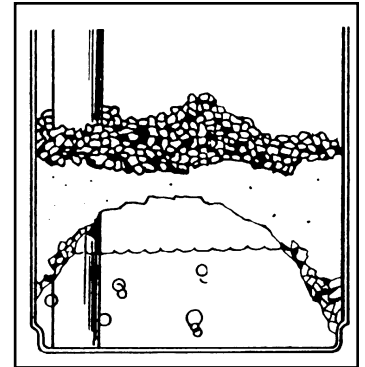

Figure 6

Care of Your Softener

To retain the attractive appearance of your new water softener, clean occasionally with mild soap solution. Do not use abrasive cleaners, ammonia or solvents. Never subject your softener to freezing or to temperatures above 49°C (120°F).

Cleaning the Injector Assembly (Figure 7)

Sediment, salt and silt will restrict or clog the injector. A clean water supply and pure salt will prevent this from happening.

The injector assembly is located on the left side of the control valve. This assembly is easy to clean.

Shut off the water supply to your softener and reduce the pressure by opening a cold soft water faucet. Using a screwdriver, remove the two screws holding the injector cover to the control valve body. Carefully remove the assembly and disassemble as shown in Figure 7. The injector orifice is removed from the valve body by carefully turning it out with a screwdriver. Remove the injector throat the same way. Carefully flush all parts including the screen. Use a mild acid such as vinegar or *Pro-Rust Out* to clean the small holes in the orifice and throat. Reassemble using the reverse procedure.

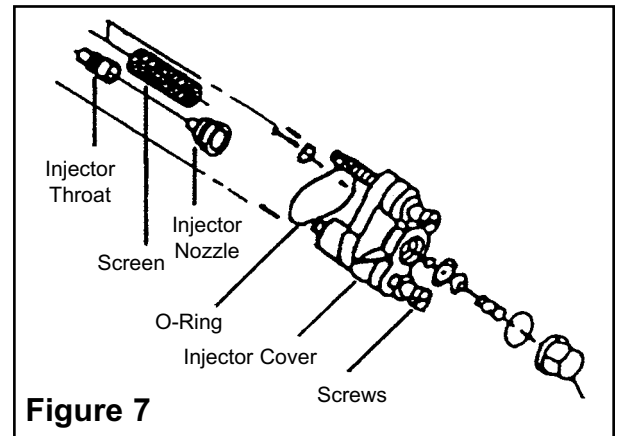

Figure 7

NOTE: The injector cover contains a factory set pressure regulator. Do not attempt to adjust this regulator.

Resin Cleaner

An approved resin cleaner **MUST** be used on a regular basis if your water supply contains iron. The amount of resin cleaner and frequency of use is determined by the quantity of iron in your water (consult your local representative or follow the directions on the resin cleaner package).

Trouble Shooting Guide

<p>1. CONDITIONER DELIVERS HARD WATER</p> <p>A. Bypass valve is open B. No salt in brine tank C. Injector or screen plugged D. Insufficient water flowing into brine tank E. Hot water tank hardness F. Leak at distributor tube G. Internal valve leak H. Flow meter jammed I. Flow meter cable disconnected or not plugged into meter cap J. Improper programming</p>	<p>A. Close bypass valve B. Add salt to brine tank and maintain salt level above water level C. Replace injectors and screen D. Check brine tank fill time and clean brine line flow tank control if plugged E. Repeated flushing of the hot water tank is required F. Make sure distributor tube is not cracked. Check O ring and tube pilot G. Replace seals and spacers and/or piston H. Remove obstruction from flow meter I. Check meter cable connection to timer and meter cap J. Reprogram the control to the proper regeneration type, inlet water hardness, capacity or flow meter size.</p>
<p>2. CONDITIONER FAILS TO REGENERATE</p> <p>A. Electrical service to unit has been interrupted B. Timer is not operating properly C. Defective valve drive motor D. Improper programming</p>	<p>A. Assure permanent electrical service (check fuse, plug, chain or switch) B. Replace timer C. Replace drive motor D. Check programming and reset as needed</p>
<p>3. UNIT USES TOO MUCH SALT</p> <p>A. Improper salt setting B. Excessive water in brine tank C. Improper programming</p>	<p>A. Check salt usage and salt setting B. See #7 C. Check programming and reset as needed</p>
<p>4. LOSS OF WATER PRESSURE</p> <p>A. Iron build-up in line to water conditioner B. Iron build-up in water conditioner C. Inlet of control plugged due to foreign material broken loose from pipes by recent work done on plumbing system</p>	<p>A. Clean line to water conditioner B. Clean control and add resin cleaner to resin bed. Increase frequency of regeneration C. Remove piston and clean control</p>
<p>5. LOSS OF RESIN THROUGH DRAIN LINE</p> <p>A. Air in water system B. Drain line flow control is too large</p>	<p>A. Assure that well system has proper air eliminator control. Check for dry well condition B. Ensure drain line flow control is sized</p>
<p>6. IRON IN CONDITIONED WATER</p> <p>A. Fouled resin bed B. Iron content exceeds recommended parameters</p>	<p>A. Check backwash, brine draw and brine tank fill. Increase frequency of regeneration. Increase backwash time B. Add iron removal filter system</p>
<p>7. EXCESSIVE WATER IN BRINE TANK</p> <p>A. Plugged drain line flow control B. Brine valve failure C. Improper programming</p>	<p>A. Clean flow control B. Replace brine valve C. Check programming and reset as needed</p>
<p>8. SALT WATER IN SERVICE LINE</p> <p>A. Plugged injector system B. Timer not operating properly C. Foreign material in brine valve D. Foreign material in brine tank flow control E. Low water pressure F. Improper programming</p>	<p>A. Clean injector and replace screen B. Replace timer C. Clean or replace brine valve D. Clean brine line flow control E. Raise water pressure F. Check programming and reset as needed</p>
<p>9. CONDITIONER FAILS TO DRAW BRINE</p> <p>A. Drain line flow control is plugged B. Injector is plugged C. Injector screen is plugged D. Line pressure is too low E. Internal control leak F. Improper programming G. Timer not operating properly</p>	<p>A. Clean drain line flow control B. Clean or replace injectors C. Replace screen D. Increase line pressure (line pressure must be at least 20 psi at all times) E. Change seals and spacers and/or piston assembly F. Check programming and reset as needed G. Replace timer</p>
<p>10. CONTROL CYCLES CONTINUOUSLY</p> <p>A. Timer not operating properly B. Faulty microswitches and/or harness C. Faulty cycle cam operation</p>	<p>A. Replace timer B. Replace faulty microswitch or harness C. Replace cycle cam or reinstall</p>
<p>11. DRAIN FLOWS CONTINUOUSLY</p> <p>A. Foreign material in control control in various regeneration positions B. Internal control leak C. Control valve jammed in brine or backwash position D. Timer motor stopped or jammed teeth E. Timer not operating properly</p>	<p>A. Remove piston assembly and inspect bore. Remove foreign material and check B. Replace seals and/or piston assembly C. Replace piston and seals and spacers D. Replace timer motor and check all gears for missing teeth E. Replace timer</p>

Guarantee

WaterGroup Companies Inc. guarantees that your new water conditioner is built of quality material and workmanship. When properly installed and maintained, it will give years of trouble free service.

Seven Year Complete Parts Guarantee:

WaterGroup Companies Inc. will replace any part which fails within 84 months from date of manufacture, as indicated by the serial number provided the failure is due to a defect in material or workmanship. The only exception shall be when proof of purchase or installation is provided and then the warranty period shall be from the date thereof.

Lifetime Guarantee on Mineral Tanks and Brine Tanks:

WaterGroup Companies Inc. will provide a replacement mineral tank or brine tank to any original equipment purchaser in possession of a tank that fails within his/her lifetime, provided that the water conditioner is at all times operated in accordance with specifications and not subject to freezing.

General Provisions:

WaterGroup Companies Inc. assumes no responsibility for consequential damage, labor or expense incurred as a result of a defect or for failure to meet the terms of these guarantees because of circumstances beyond its control.

WaterGroup